



# PM General Service Safety

## Section 02-01-01

Komatsu has made every effort to make this manual as accurate as possible based on the information available at the time of publication and printing. Continuous improvement and advancement of product design may cause changes to machines which may not have been included in this publication. Komatsu reserves the right to make changes and improvements at any time. To ensure the most current information, please contact your service center.

## Table of Contents

<b>Scope of This Publication</b> .....	<b>3</b>
<b>Customer Responsibilities and Warranty Advisories</b> .....	<b>3</b>
<b>Safety</b> .....	<b>5</b>
Safety, Warnings and Cautions .....	5
<b>Establishing a Comprehensive Maintenance Program</b> .....	<b>7</b>
Four Important Requirements for an Effective PM Program .....	7
Personnel.....	7
Management Response .....	7
Maintenance Records.....	7
Scheduled Downtime.....	8
Modular Preventive Maintenance Schedules for Loaders .....	8
Data Downloads.....	8
<b>Service Switches and Connections</b> .....	<b>9</b>
Component Heater Connections (Optional) .....	10
Central Service System (Optional) .....	11
Isolation and Control Switches Assembly.....	12
Lubrication Cycle Switch (#1 in Figure 6 “Isolation and control switches assembly”).....	13
KLENZ™ Enable Switch (#2 in Figure 6 “Isolation and control switches assembly”).....	14
Ladder Light Switch (#3 in Figure 6 “Isolation and control switches assembly”).....	14
Maintenance Lights Switch (#4 in Figure 6 “Isolation and control switches assembly”).....	15
Jump Start Socket (Optional) (#5 in Figure 6 “Isolation and control switches assembly”).....	15
Starter Isolator Indication Light (#6 in Figure 6 “Isolation and control switches assembly”).....	15
Starter Isolation Switch (#7 in Figure 6 “Isolation and control switches assembly”).....	15
Battery Isolation Switch (#8 in Figure 6 “Isolation and control switches assembly”).....	15
Battery Isolator Indication Light (#9 in Figure 6 “Isolation and control switches assembly”).....	15
<b>Retrieving and Towing</b> .....	<b>17</b>
Retrieving and Towing the Machine .....	17

## List of Figures

Figure 1.	Service switches and connections – approximate machine location .....	9
Figure 2.	Component heater connection box .....	10
Figure 3.	Central service system (optional) - typical .....	11
Figure 4.	Hydraulic reservoir pressure release valves .....	11
Figure 5.	Radiator surge tank release ball valve .....	12
Figure 6.	Isolation and control switches assembly.....	12
Figure 7.	Lubrication cycle switch locations .....	13
Figure 8.	Towing points – rear of machine without bumper counterweight.....	17
Figure 9.	Towing points – rear of machine with bumper counterweight.....	18

This Page Intentionally Left Blank

## Scope of This Publication

**PREVENTIVE MAINTENANCE GENERAL SERVICE SAFETY** provides instructions for locating service switches and connections, jump starting, and other instructions relating to field service. The loader's massive size and various systems require a thorough knowledge of varied and complex maintenance and safety procedures during routine maintenance. Only trained and experienced personnel should be allowed to inspect and service the machine. The Preventive Maintenance publication is divided into ten parts for easy reference:

**GENERAL SERVICE SAFETY** provides instructions for locating service switches and connections, jacking instructions, and other instructions relating to field service.

**BREAK-IN PERIOD** provides important instructions for service that must be performed from the initial commissioning of the machine to 1000 hours of service. A **BREAK-IN PERIOD SERVICE PROCEDURE CHECKLIST** is provided. Print the checklist from the electronic manual for use during the important break-in period.

**MODULAR PREVENTIVE MAINTENANCE SCHEDULES** provides instructions for service intervals for the various systems on the loader. Print the schedules from the electronic manual for use in machine maintenance.

**LUBRICATION AND SERVICE** provides instructions on recommended lubricants and fluids, the automatic lubrication system, and for establishing an on-going lubricating oil analysis program.

**HYDRAULIC SYSTEM SERVICE REQUIREMENTS AND OPERATIONAL CONCERNS** provides instructions on servicing the hydraulic system and hydraulic pump gearbox.

**PLANETARY DRIVE MAINTENANCE** provides instructions on the lubrication, filtration system service requirements and rotation of the planetary drives.

**CLEANING AND COMPONENT INSPECTION** provides instructions on cleaning machine and making important structural inspections.

**24 VOLT DC SYSTEM** provides instructions on maintaining the loader's batteries and battery charging alternator.

## Customer Responsibilities and Warranty Advisories

The P&H wheel loaders are warranted in accordance with the warranty policy provided with the machine. The recommended operating and maintenance procedures set forth shall be followed to ensure warranty coverage is not jeopardized. Failure to comply with recommended operating and maintenance procedures may void machine warranty.

Any questions or problems relating to warranty policy or administration should be directed to Komatsu Service Center. Include the model and serial number, in-service date of the machine, and hour meter reading. **We especially draw your attention to the following safety advisors.**

This Page Intentionally Left Blank

# Safety

This publication contains special instructions that pertain to safety, operation, maintenance, and repair of the machine. Listed below are the signal words and symbols that precede these instructions and their meanings:


## DANGER

- The danger label indicates a hazardous situation which, if not avoided, will result in death or serious injury.

## WARNING

- The warning label indicates a hazardous situation which, if not avoided, could result in death or serious injury.

## CAUTION

- The caution label, used with the safety alert symbol indicates a hazardous situation which, if not avoided, could result in minor or moderate injury (includes the safety alert symbol .

## CAUTION

- The caution label (without safety alert symbol) is used to address practices not related to personal injury – only equipment damage.

## NOTICE

The NOTICE graphic is to indicate areas of importance to the reader that are not related to personal injury or machine damage.

## Safety, Warnings and Cautions

### WARNING

#### ELECTRICAL SHOCK HAZARD

- Electrical shock hazard exists when working on heaters. Heaters may operate as high as 240 volts. Heaters should never be worked on, replaced, or repaired unless they are disconnected from the power source and disabled from operation. Failure to disconnect before working on heaters can cause electrical hazards resulting in serious injury or death.

#### HEARING DAMAGE OR EYE INJURY HAZARDS

- Hearing damage or eye injury hazard exists if the KLENZ™ Enable Switch is not turned to the OFF position before performing any service work to the machine. When the “KLENZ™” pulse valves activate, the sound is a sharp “boom” (actually a shock wave). The shock wave can cause injury to the eardrum. Wear the proper hearing protection during operational testing and when working around an operational system. Bleed air pressure to zero psig before performing any service or repair work to the KLENZ™ system or other components powered by the compressed air system. Failure to bleed the air pressure to zero in the compressed air system can cause hearing damage or eye injury from a sonic blast within the KLENZ system resulting in ear drum injury.

**LEAD PRESENCE HAZARD**

- Battery posts, terminals and related accessories contain lead and lead compounds, chemicals known to the State of California, USA to cause cancer and birth defects or other reproductive harm. Do not handle battery posts, terminals or related accessories containing lead or lead compounds without wearing proper personal protective equipment (PPE) as required by local rules, regulations, or policies.

**FALL HAZARD OR STRUCK-BY HAZARD**

- Fall hazard or struck by foreign objects hazard is possible while climbing the hydraulic reservoir ladder near the KLENZ™ air filtration system. LINCS boots completely down after the machine key is turned to the OFF position. The purge cycle will continue until LINCS is booted completely down or until the compressed air system pressure drops below 90 psi (6.2 bar) (even if the machine key is in the OFF position and the engine is not running). The “KLENZ™” filtration system will emit a loud “boom” and blow dust from the bottom of the hopper during the purge cycle. This process may be startling and present a hazard to anyone climbing the ladder adjacent to the filtration system. Turn the KLENZ™ Enable Switch OFF before climbing the ladder. The loud “boom” could cause a person on the ladder to be startled and lose their grip, resulting in a fall. DO NOT climb the hydraulic reservoir ladder or stand near the bottom of the ladder of an operational machine unless the KLENZ™ Enable Switch is in the OFF position, except in an emergency situation. Serious injury from a fall or being struck by foreign objects is possible, resulting in serious injury or death.

## CAUTION

**FLUID PRESSURE**

- Be sure to relieve pressure in the hydraulic reservoir and in the radiator by opening the manual air release valve provided for each component before, attaching hose to the quick couplings (refer to illustrations “Hydraulic reservoir pressure release valve” and “Radiator surge tank release ball valve”).

**ENVIRONMENTAL**

- Disposal of used oil, hydraulic fluid and engine coolant is subject to federal, state, and local environmental regulations. Dispose of these items properly through approved reclamation facilities per applicable regulations. DO NOT flush or pour these items into streams or sewer systems.

# Establishing a Comprehensive Maintenance Program

A comprehensive preventive maintenance (PM) program will pay dividends to the owners over the life of the machine in several ways:

- Fewer major component repairs and fewer repetitive repairs.
- Increased machine life and greater availability.
- Less unscheduled downtime.
- Reduced maintenance costs, labor, and materials.
- Greater safety for workers and improved protection for equipment.

## Four Important Requirements for an Effective PM Program

### Personnel

The operator should accept the responsibility of walking around the machine to inspect daily checkpoints. The instructions contained in this manual and the MODULAR PREVENTIVE MAINTENANCE SCHEDULES, located within this section, should be read, understood, and kept handy for further reference. A copy should be provided for each person with these responsibilities.

### Management Response

The second requirement in an effective preventive maintenance program is quick and positive response to a known or potential problem. If the operator indicates a potential problem, action should be taken immediately - even if it is a minor adjustment. Any problem not taken care of in a timely manner has the potential of causing a major breakdown.

### Maintenance Records

The third requirement in an effective preventive maintenance program is a system for recording material and labor costs. Well-kept records can serve as guides indicating when to replace or rebuild a component. Keeping good records of maintenance performed on the machine also provides a basis for planning and custom tailoring a preventive maintenance program to the job and the environment in which the machine is working. For example, it may be determined through records that the air filter should be replaced more periodically than the engine manufacturer recommends. Though this may be a small adjustment, it can be one that leads to increased engine life. This principal can be applied to other major components of the machine, and as all aspects of the maintenance program are fine-tuned, the result is less breakdowns and controlled expense versus unexpected downtime.

Records may also indicate a trend for the type of maintenance program for the machine beyond what is specified herein. The maintenance schedules contained in this manual are based on hours and estimates of calendar time. These hours would be accumulated under normal operating conditions. However, because of certain applications, duty cycles, or varying conditions, the need for maintenance cannot always be measured in hours alone. In these cases a weekly, twice-weekly, or monthly schedule may be more applicable.

## Scheduled Downtime

**Any well-designed PM program should allow for production scheduling to accommodate the required maintenance downtime.** Accurate record keeping and analysis of inspection data, repair downtime, component failure, spare parts inventory, operating policies and labor costs involved should all be considered in the overall scope of the PM program.

## Modular Preventive Maintenance Schedules for Loaders

Recommendations for regular preventive maintenance inspections and services based on normal operating conditions are provided in the Section 02-01 "MODULAR PREVENTIVE MAINTENANCE SCHEDULES"

This PM reflects combined information from both engine manufacturers (Detroit Diesel and Cummins). For exact service intervals, follow the manufacturer's recommendations. Vary the suggested intervals more frequently, as required, when the machine is subject to extremes of temperature, prolonged operation, sandy or dusty conditions, or exposure to moisture.

The preventive maintenance schedules provided in this publication primarily cover:

- Inspections - structural, mechanical, electrical and electronic.
- Lubrication schedules and requirements.
- Adjustments.
- Tire and wheel maintenance.

**Make copies of the schedules and use them as check lists in the routine maintenance of the machine.**

The schedules also provide guidelines for various hourly usage intervals. The owner's use of the machine in production scheduling should also be considered in regards to the hourly intervals shown on the schedules.

The following schedules are provided:

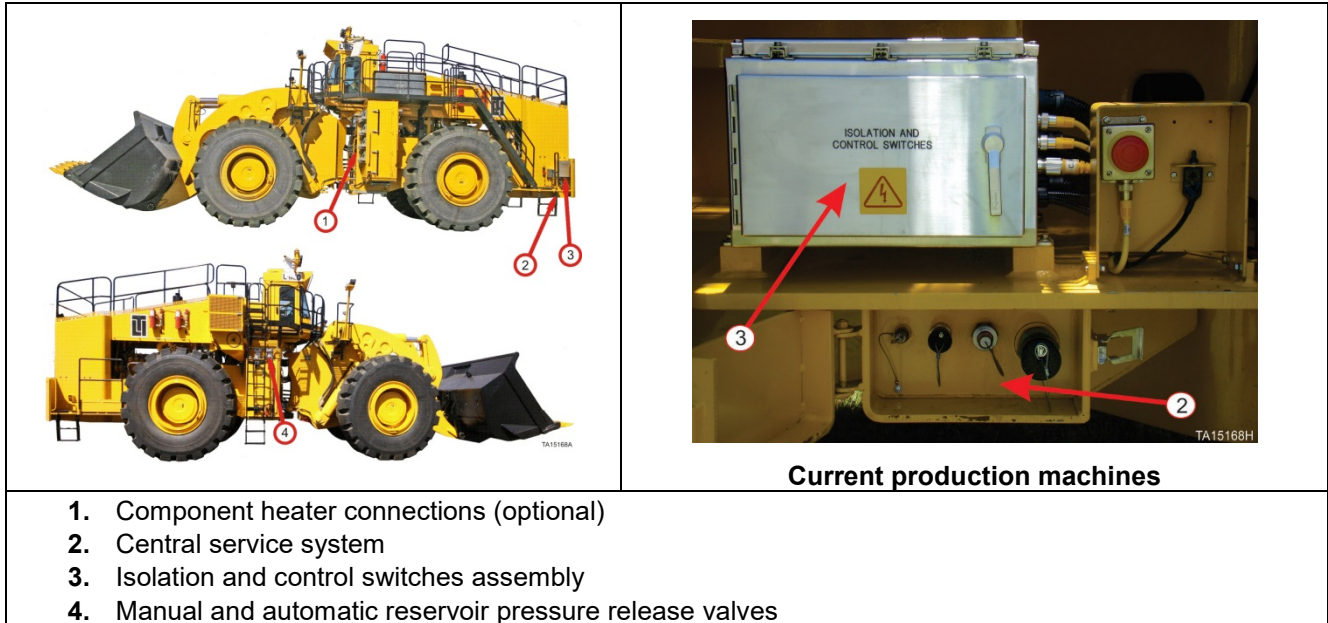
- Daily and Pre-shift Inspections and Services
- 100-Hour or Weekly Inspections and Services
- 500-Hour Inspections and Services
- 1000-Hour Inspections and Services
- 1500-Hour Inspections and Services
- 2000-Hour Inspections and Services
- 5000-Hour Inspections and Services
- 6000-Hour Inspections and Services
- 10000-Hour Inspections and Services
- 12,000-Hour Inspections and Services
- 20,000-Hour Inspections and Services

## Data Downloads

Operational and production data stored in the LINC<sup>S</sup>® computer system and the Detroit Diesel or Cummins computer systems (as applicable) should be downloaded every month or every 250 hours of operation. This data can provide key indicators for use in customizing a preventive maintenance program and alerts to potential problems. Monthly LINC<sup>S</sup>® data downloads are required to meet Komatsu warranty requirements. Contact the Komatsu Service Center and the closest authorized engine Service Center for assistance in downloading engine operational data.

# Service Switches and Connections

Several switches and connections are provided on the machine for use in maintenance and repair operations. Use of these switches and connections is recommended, as their primary function is to ensure a safe and productive working environment.



1. Component heater connections (optional)
2. Central service system
3. Isolation and control switches assembly
4. Manual and automatic reservoir pressure release valves

**Figure 1. Service switches and connections – approximate machine location**

**Component Heater Connections (Optional)** A 220-volt receptacle is optionally provided for connecting the optional hydraulic reservoir, axles, battery, grease reservoir, and fuel reservoir heaters. Power connections are provided for supplying power to the optional engine coolant and oil 220-volt heaters. These connections are located on the rear frame, inside the pivot area, on the left side of the machine. Connections are accessible from ground level.



Component heater connection box is located within articulation area-left side of machine.

Figure 2. Component heater connection box

## **WARNING**

Electrical shock hazard exists when working on heaters. Heaters may operate as high as 240 volts. Heaters should never be worked on, replaced, or repaired unless they are disconnected from the power source and disabled from operation. Failure to disconnect before working on heaters can cause electrical hazards resulting in serious injury or death.

## Central Service System (Optional)

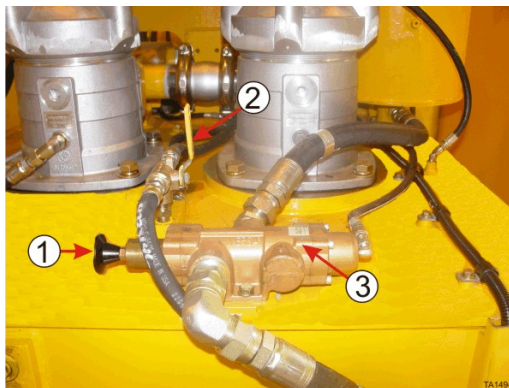
The optional central service system is housed inside a protective box and mounted at the left rear of the machine. The central service system provides quick-coupling connections for refilling the fuel reservoir, engine crankcase, hydraulic reservoir, and engine coolant. Different quick couplers are provided for each component to ensure accuracy in filling. Refer to illustration “Service switches and connections – approximate machine location” for location on the machine.

### CAUTION

Be sure to relieve pressure in the hydraulic reservoir and in the radiator by opening the manual air release valve provided for each component before attaching hose to the quick couplings (refer to illustrations “Hydraulic reservoir pressure release valve” and “Radiator surge tank release ball valve”).

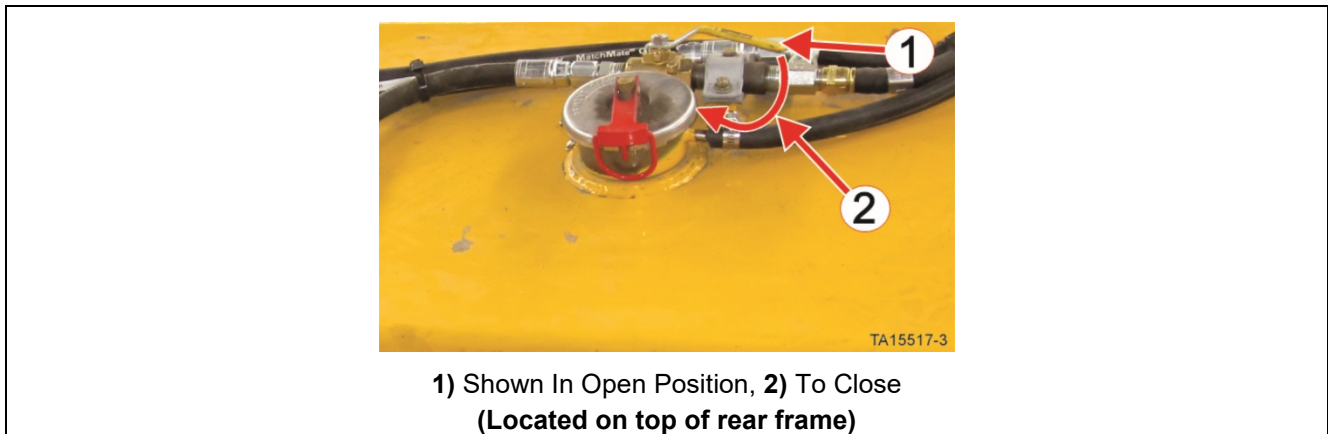


Figure 3. Central service system (optional) - typical



1) Reset Button, 2) Manual Release Valve, 3) Automatic Release Valve  
(Located on top of hydraulic reservoir)

Figure 4. Hydraulic reservoir pressure release valves

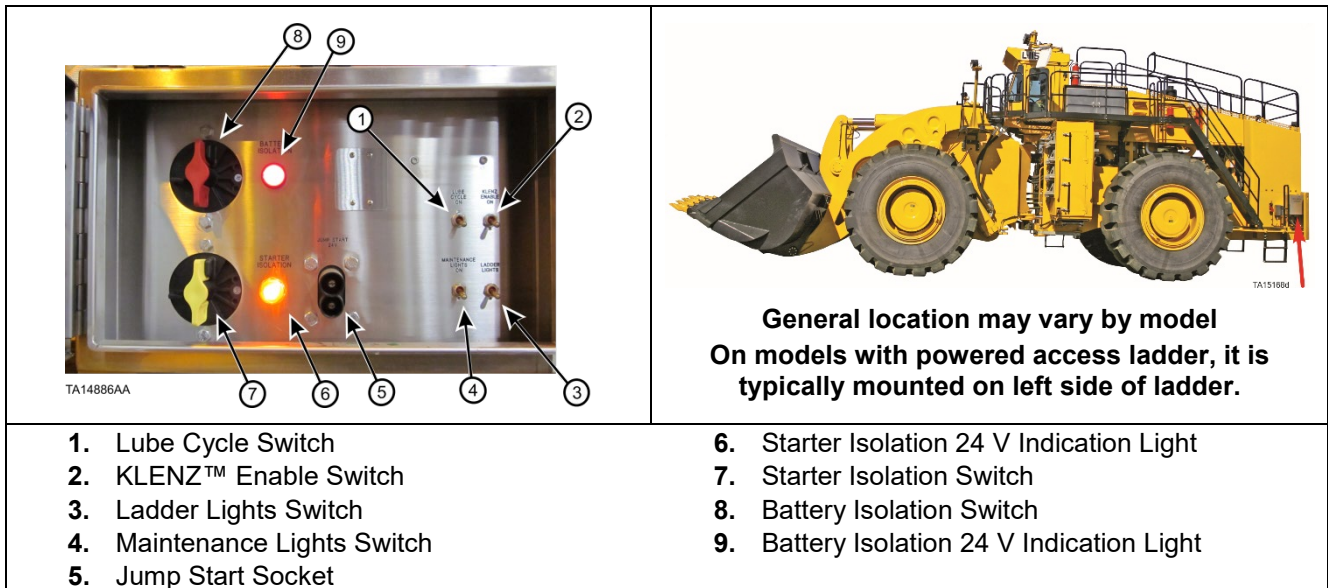


1) Shown In Open Position, 2) To Close  
(Located on top of rear frame)

**Figure 5. Radiator surge tank release ball valve**

## Isolation and Control Switches Assembly

The Isolation and Service Switches Assembly contains components useful to maintain safety during machine maintenance. It is located at the left rear of the machine.



**General location may vary by model  
On models with powered access ladder, it is  
typically mounted on left side of ladder.**

- |  |  |
|--|--|
| <ul style="list-style-type: none"> <li>1. Lube Cycle Switch</li> <li>2. KLENZ™ Enable Switch</li> <li>3. Ladder Lights Switch</li> <li>4. Maintenance Lights Switch</li> <li>5. Jump Start Socket</li> </ul> | <ul style="list-style-type: none"> <li>6. Starter Isolation 24 V Indication Light</li> <li>7. Starter Isolation Switch</li> <li>8. Battery Isolation Switch</li> <li>9. Battery Isolation 24 V Indication Light</li> </ul> |
|--|--|

**Figure 6. Isolation and control switches assembly**

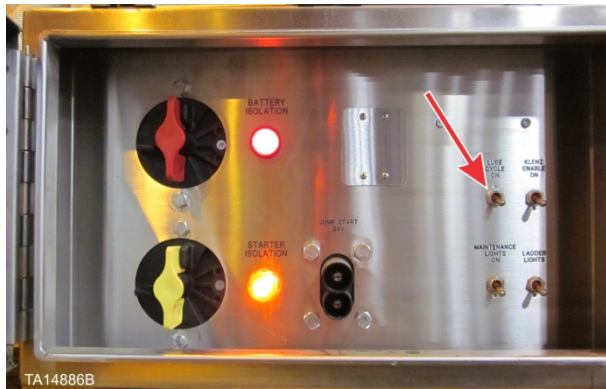
# Lubrication Cycle Switch (#1 in Figure 6 “Isolation and control switches assembly”)

Because the automatic lubrication system is hydraulically powered, the engine must be running for the Lubrication Cycle Switch to operate. When any Lubrication Cycle Switch is pressed to the ON position and the drive system is engaged, the automatic lubrication system will cycle. The switch on the Overhead Panel has a built in LED that will illuminate during any auto lube system cycle (manual or timed).

## NOTICE

There are three Lubrication Cycle Switches. They are located:

- Inside the Isolation and Control Switch Box on the left rear of the loader.
- On the overhead panel in the operator’s cab.
- Inside the front frame, above the grease reservoir on the front frame wall.



Lubrication switch inside isolation and control switches assembly



1) Lubrication Cycle Switch on overhead panel in operator cab



Lubrication cycle switch in front frame

Figure 7. Lubrication cycle switch locations

## **KLENZ™ Enable Switch (#2 in Figure 6 “Isolation and control switches assembly”)**

The Filter Purge Timer Switch is a two-position maintained toggle switch. The Filter Purge Timer Switch turns OFF the purge cycle of the Komatsu Cartridge Filtration System (KLENZ™ system). Unless turned OFF, the purge cycle will continue until compressed air system pressure drops below the set point. When the purge occurs, the filter will emit a loud “boom” and dirt will be blown from the hopper. The noise can be startling and dirt blowing from the hopper can present a hazard to persons climbing the ladder adjacent to the KLENZ™ system or standing under the hopper.

### **WARNING**

Fall hazard or struck by foreign objects hazard is possible while climbing the hydraulic reservoir ladder near the KLENZ™ air filtration system. LINCS boots completely down after the machine key is turned to the OFF position. The purge cycle will continue until LINCS is booted completely down or until the compressed air system pressure drops below 90 psi (6.2 bar) (even if the machine key is in the OFF position and the engine is not running). The “KLENZ™” filtration system will emit a loud “boom” and blow dust from the bottom of the hopper during the purge cycle. This process may be startling and present a hazard to anyone climbing the ladder adjacent to the filtration system. Turn the KLENZ™ Enable Switch OFF before climbing the ladder. The loud “boom” could cause a person on the ladder to be startled and lose their grip, resulting in a fall. **DO NOT** climb the hydraulic reservoir ladder or stand near the bottom of the ladder of an operational machine unless the KLENZ™ Enable Switch is in the OFF position, except in an emergency situation. Serious injury from a fall or being struck by foreign objects is possible, resulting in serious injury or death.

### **WARNING**

Hearing damage or eye injury hazard exists if the KLENZ™ Enable Switch is not turned to the OFF position before performing any service work to the machine. When the “KLENZ™” pulse valves activate, the sound is a sharp “boom” (actually a shock wave). The shock wave can cause injury to the eardrum. Wear the proper hearing protection during operational testing and when working around an operational system. Bleed air pressure to zero psig before performing any service or repair work to the KLENZ™ system or other components powered by the compressed air system. Failure to bleed the air pressure to zero in the compressed air system can cause hearing damage or eye injury from a sonic blast within the KLENZ system resulting in ear drum injury.

### **NOTICE**

When the filter purge cycle is turned off, a notice screen, with a text message indicating the purge cycle is off, will appear on the LINCS II® computer monitor in the operator’s cab. **BE SURE** to turn the filter purge timer switch to the ON position and close the manual air release valve before returning the machine to service.

## **Ladder Light Switch (#3 in Figure 6 “Isolation and control switches assembly”)**

The machine is equipped with 24-VDC lights for illuminating the access ladder, staircase and work service areas. The ladder and staircase lights are mounted on top of the rear frame and on top of the operator’s cab. The work area lights are mounted on each side of the radiator, mid-engine, near the generator, and in the front frame. Two, 2-position, 3-way switches are provided to turn the lights on and off. The upper switch is mounted behind the cab. The lower switch is located in the Control Switch Box. The switches are labeled “Ladder Lights”.

## Maintenance Lights Switch (#4 in Figure 6 “Isolation and control switches assembly”)

The Maintenance Lights Switch is a two-position maintained toggle switch that controls the 24V DC service work lights mounted on each side of the radiator, mid-engine, near the generator, and in the front frame. The key switch on the operator’s console does not have to be in the ON position to operate the maintenance lights, but the Battery Isolation Switch must be in the ON position.

## Jump Start Socket (Optional) (#5 in Figure 6 “Isolation and control switches assembly”)

It is possible to damage the electronic controls of the machine and engine if jumper cables are connected improperly or arcing occurs. Therefore, Komatsu recommends that the machine only be jump started or used to jumpstart another vehicle with the optional jumpstart socket.

### **WARNING**

**Battery posts, terminals and related accessories contain lead and lead compounds, chemicals known to the State of California, USA to cause cancer and birth defects or other reproductive harm. Do not handle battery posts, terminals or related accessories containing lead or lead compounds without wearing proper personal protective equipment (PPE) as required by local rules, regulations, or policies.**

## Starter Isolator Indication Light (#6 in Figure 6 “Isolation and control switches assembly”)

The amber light is illuminated when the engine cranking function is enabled.

## Starter Isolation Switch (#7 in Figure 6 “Isolation and control switches assembly”)

For maintenance when 24 volts is required (for 24 volt circuit testing or for repairs at night in the pit), the YELLOW Starter Isolation Switch can be turned to the OFF position. When the YELLOW Starter Isolation Switch is turned OFF, there will be 24 volt power available for all machine functions, except engine cranking. The switch can be locked in the OFF position if desired. When the Starter Isolation Switch is turned to the ON position, the engine cranking function is enabled.

## Battery Isolation Switch (#8 in Figure 6 “Isolation and control switches assembly”)

If necessary to leave the machine unattended or if necessary to eliminate all electrical energy sources, turn the RED Battery Isolation Switch to the OFF position. This switch can be locked in the OFF position if desired.

## Battery Isolator Indication Light (#9 in Figure 6 “Isolation and control switches assembly”)

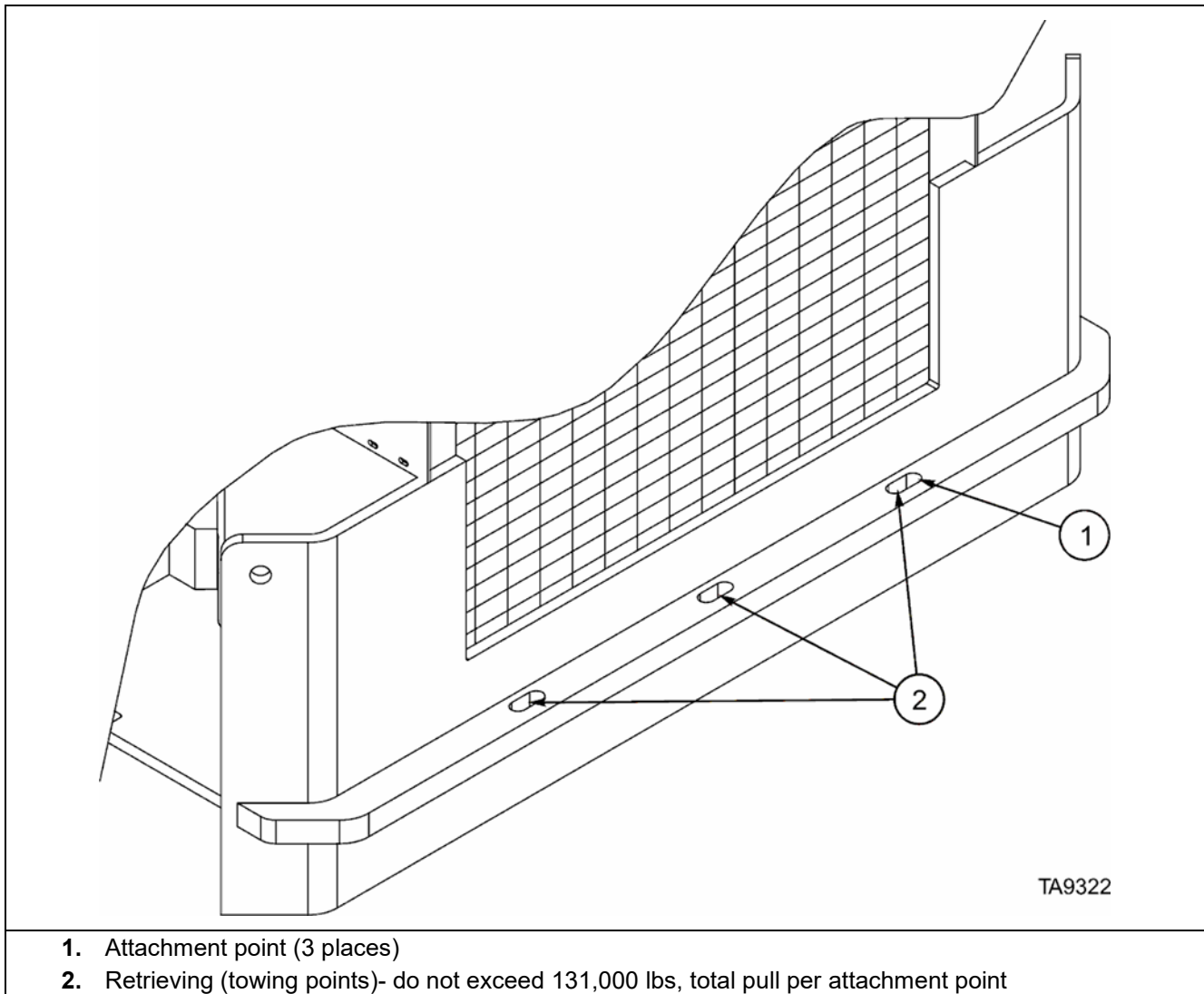
When the Battery Isolation Switch is moved to the ON position, 24V battery power is enabled and the RED light illuminates.

This Page Intentionally Left Blank

# Retrieving and Towing

## Retrieving and Towing the Machine

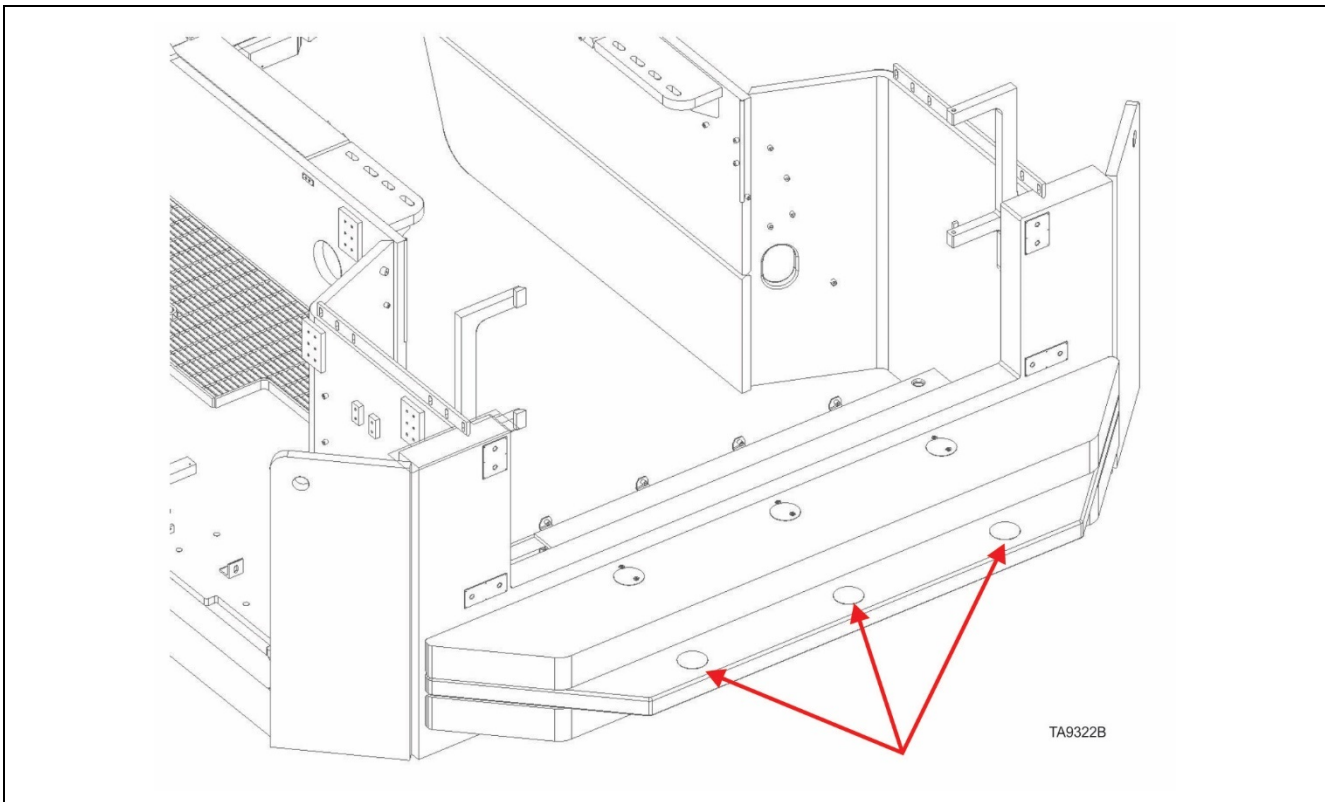
In the event the machine is disabled in the workplace, the rear bumper of the machine is equipped with three points for attachment of towing devices. It is essential to not exceed 131,000 lbs. of pull per attachment point. Refer to illustration below for towing points.



**Figure 8. Towing points – rear of machine without bumper counterweight**

## NOTICE

The rear bumper shall not be used to lift the rear frame. Lifting points are provided on the rear of the rear frame.



3. Attachment point (3 places)
4. Retrieving (towing points)- do not exceed 131,000 lbs, total pull per attachment point

**Figure 9. Towing points – rear of machine with bumper counterweight**